

Special lubricants for
**Ships and
Offshore
Platforms**





YOUR GLOBAL
LUBRICATION
PARTNER
LUBCHEM

For Better Environment

YOUR GLOBAL LUBRICATION PARTNER LUBCHEM

LUBCHEM was established in order to respond to customer's need which is demanding on high quality lubricants using knowledge base and export in global market.

Since foundation of company, we have been committed to providing our customers with eco-friendly products at reasonable price by the most economical method and currently, we have a leading role in the foreign exportation of lubricants based on accumulated Knowhow.

We, Lubchem lubrication will be born again as the enterprise with international competitiveness by aggressive technology development and investment in high-performance lubricants.

In spite of the external economic difficult situation in the world for the last 10 years, Lubchem have led to remarkable progress in both quality and quantity thanks to one step ahead of technology and competitiveness through continuous investment and this result could not be found easily in other lubricant manufactures.

Now, thanks to our continuous technology development, we could supply the lubricants that meet customer requirements by quickly and in entire industries with a reasonable price.

| OUR CLIENT |

- Steel industry | Posco, Hyundai, Dongguk steel etc.
- Automotive industry | Hyundai & Kia motors, GM, GMB, Delphi, PH, Hwashin, Donghej, Central, SL, Ijin etc. and other vendors
- Electrical | Samsung, LG, Daewoo, Toshiba etc.
- Bearing | Schaeffler(LUK, INA, FAG), GMB
- Textile | textile machin makers and textile production, finishing factory
- Cement industry | Dongyang, Ssangyong, Asia, Hanlla, Sungshin
- Domestic wholesale and resellers
- Overseas distributors





The importance to use special lubricants in marine industry

Special lubricant applied in the harsh conditions at sea Ship and offshore equipment are exposed to extremely harsh condition and it is very important that they run smoothly and reliably.

Through the proper selection of lubricants Reliable operation of the machine at sea is a very important and at the same time of a ship or offshore equipment are exposed to extremely harsh conditions, Correct lubricant vessels and equipment failures and no longer re-lubrication intervals than through the selection operation is cost savings, particularly important in terms of driving safety and minimize environmental pollution.

The lubrication conditions are especially harsh as ever at sea, sometimes in very cold or tropical regions exposed to high temperatures as well as wind and waves, many operating equipment installed on the ship due to salt water, etc. are constantly exposed to high mechanical loads and harsh environments, become more cautious in selecting a lubricant, Under these circumstances, the life of a typical lubricant is inevitably very short, Cranes, winches, or damage to the drive motor on disruptions in operations in addition to high repair costs is inevitable. And as more stringent environmental protection regulations are not only a burden on the offshore shipowner may In order to satisfy all these requirements, such as the role of the special lubricant manufacturer company it will be further expanded in the future. Our special lubricants are being expanded usage and environmental holding a variety of special lubricants to minimize the impact and at the same time continue to develop a variety of products and that applied in the present field to the adhesive enemy at sea.

Specialty lubricants can be used while increasing the reliability of the components satisfy the environmental regulations, reducing overall operating costs.

Benefits from using of LUBCEHM special lubricants

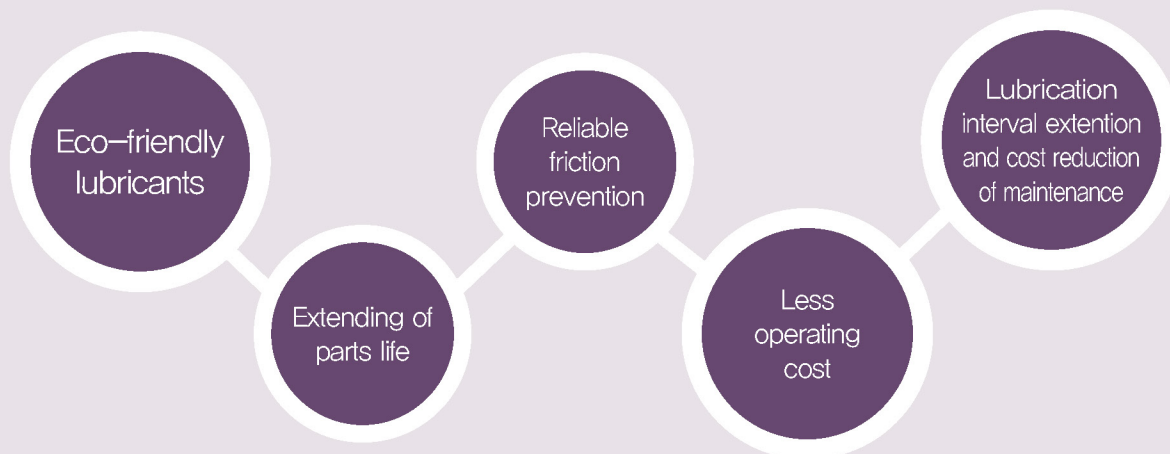



Special lubricants for ships and offshore platforms

Parts	Lubricating points	Requirements	Recommendation
Diesel engine	open gear of flywheels	highly adhesive grease	LUBCHEM BE 2102
Transmission	reduction gear boxes	mineral gear oil	LUBCHEM GM 100/150
		synthetic gear oil, longer service life	LUBCHEM GM 100/150/220 S
	enclosed gear boxes	mineral gear oil	LUBCHEM GM 100/150
		synthetic gear oil, longer service life	LUBCHEM GM 100/150/220 S
	gear coupling – oil lubrication	highly adhesive oil, solid lubricants	LUBCHEM GE 5500 MF
		low viscosity gear oil	LUBCHEM GM 460
	gear coupling – grease lubrication	very soft grease and contained solid lubricants	LUBCHEM CSG 2100
high-load grease contained solid lubricants		LUBCHEM BE 6151	
very soft grease, without solid lubricants		LUBCHEM GE 2140	
	split roller bearings for propeller shafts		LUBCHEM BH 6032 EP
Azipod	slewing bearing with gear teeth	PAO synthetic oil	LUBCHEM GM 320 S
	thrust bearings	PAO synthetic oil	LUBCHEM GM 320 S
	propeller shaft bearings	PAO synthetic oil	LUBCHEM GM 320 S



ship engine

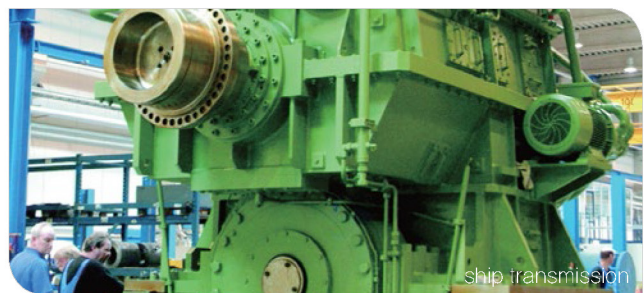

ship transmission

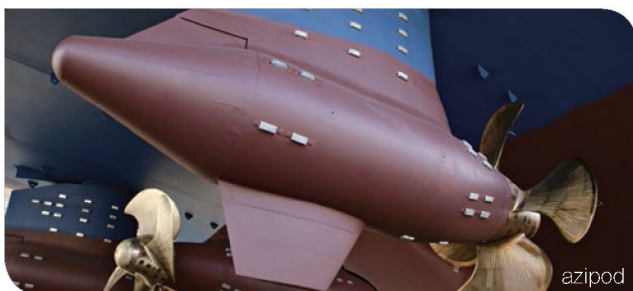

azipod



propeller shaft



Special lubricants for ships and offshore platforms

Parts	Lubricating points	Requirements	Recommendation
Anchor winch / mooring winch	Open gears / Running– in		LUBCHEM BSG 2107 G
	Open gear Central lubrication systems or manual	very soft adhseive lubricant	LUBCHEM BE 2101
		very soft adhseive lubricant	LUBCHEM BE 2102
	Enclosed gear box	synthetic gear oils	LUBCHEM GM 220/320 S
	Bearing / Rolling bearings	For rolling bearing subjected to low speed, high load	LUBCHEM BE 2102
	Bearing / Sliding bearing	For rolling bearing subjected to low speed, high load	LUBCHEM BE 2102
		high speed, low temperature	LUBCHEM BH 6032 EP
Anchor winch spooling		LUBCHEM BE 2102	
Hydraulic motors	Hydraulic oils – mineral oil based	LUBCHEM HD 32/46/68	

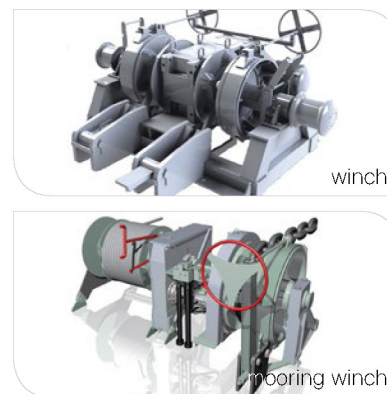
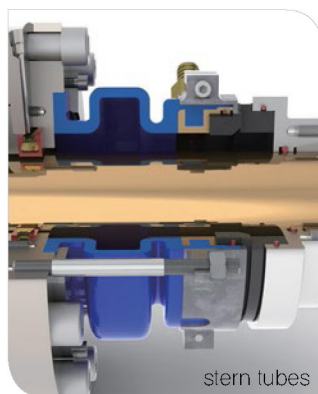

Parts	Lubricating points	Requirements	Recommendation
Compressor	Gas compressor		LUBCHEM PSI 68/100/150/220
	Air–compressor		LUBCHEM SH 32/46/68/100
Electric motor	Electrica motor bearings		LUBCHEM BE 6032 EP
Chains	Chains – grease lubrication		ASTRO MPC 6102 N
	Chains – oil lubrication	solid lubricants	LUBCHEM GE 5500 MF
LUBCHEM GE 5500 S			
Steel cables	Steel cables		LUBCHEM BE 2102
Assembly paste	Screw pastes		LUBCHEM PT 6070 MR
	Steel screw paste		LUBCHEM PT 6080 PE



Parts	Lubricating points	Requirements	Recommendation
Fairleads	Bearing – plain bearings	high laod , low speed	LUBCHEM BE 2102
		low and high speed plain bearing	LUBCHEM BE 6032 EP
Deck and offshore cranes	opne gears at slewing bearing and drive pinion		LUBCHEM BE 2102
	Open gear's on hoisting winches	very soft grease applicable through central lubrication systems down to -10°C	LUBCHEM BE 2101
		very soft grease applicable through central lubrication systems down to 0°C	LUBCHEM BE 2102
	Bearing – rolling bearings	low speed and high-load	LUBCHEM BE 2102
		low speed at low temp	LUBCHEM BE 6032 EP
	Bearing – slidign bearings	low speed and high load	LUBCHEM BE 2102
		low speed and high speed at low temp	LUBCHEM BE 6032 EP
Enclosed gear		LUBCHEM GM 150 S	
Hydraulic motor	Hydraulic oils – mineral oil based	LUBCHEM HD 32	
Towing pins and shark jaws	Bronze plain bearing / bushings		LUBCHEM BE 2102
Container lashing supplies	Twistlock		LUBCHEM BE 2102
	Tumbuckle threads		LUBCHEM BE 2102





Product details

Product Name	Properties
ASTRO MPC 6102 N	Special grease for medium and low speed, high load rolling and plain bearings, offering good wear protection properties and adhesiveness and anti-corrosion. Due to excellent adhesiveness, applicable to steel cable grease, contained solid lubricants Nano WS2 for emergency lubrication and surface reconditioning effect.
LUBCHEM BE 2101	White adhesive lubricating grease for open gears with very good load-carrying capacity and wear protection. The product has the same properties as LUBCHEM BE 2102, but its consistency is softer. Applicable through central lubrication systems down to approx. -10°C.
LUBCHEM BE 2102	White adhesive grease for open gears with very good load-carrying capacity and very good wear protection due to selected solid lubricants and additives. Good wear protection, also for highly loaded rolling and plain bearings at low speeds (not suitable for high speed factors). Very good adhesion, also at low temperatures (e.g. intense sunlight, tropical climate zones). No dripping or flinging off, reducing lubricant consumption. Very good water resistance and good corrosion protection in contact with seawater. Its white colour facilitates simple checks of load-carrying patterns (as it is the contrast to the dark tooth flank surface). Applicable through central lubrication systems down to approx. 0°C. Also available as spray. Clean handling, particularly suitable as rope lubricant for cruise ships as it is white and free from graphite.
LUBCHEM BH 6032 EP	Very versatile long-term lubricating grease, especially for rolling bearings with a high percentage of sliding friction (e.g. cylindrical roller bearings). It can be used for both low and high-speed bearings subject to high or low temperatures. Another possible use is the long-term lubrication of traction motor bearings. The special additivation extends component lifetime. Low maintenance requirements due to the long grease lifetime. The product offers good water resistance and good corrosion protection in contact with seawater.
LUBCHEM BSG 2107 G	Running-in lubricant for open gears. Tooth flanks are levelled by means of controlled micro wear under load during operation. An increased contact ratio of the load-carrying tooth flanks of approx. 80 % can be obtained, largely avoiding overloads and gear damage. Once running-in is completed, change over to operational lubrication. The changeover can be undertaken without prior cleaning. Please use LUBCHEM CSG 2100
LUBCHEM CSG 2100	Operational lubricant for highly loaded gear teeth ensuring long drive lifetime at low lubricant consumption, hence contributing to operating cost savings.
LUBCHEM BE 6151 MG	Heavy-duty grease with good adhesion. Solid lubricant with emergency lubricating properties for high operational reliability.



Composition	Specification
Mineral oil, Li-comp., solid lubricant Nano WS2	- Consistency grade ASTM D 1092 : NLGI 2 - Base oil @40 °C ASTM D-445: Approx. 500 mm ² /s - Service temperature: -15 ~ 150 °C
Mineral oil, Al-comp.	- Consistency grade ASTM D 1092 : NLGI 1 - Base oil @40 °C ASTM D-445: Approx. 500 mm ² /s - Service temperature: -10 ~ 150 °C
Mineral oil, Al-comp.	- Consistency grade ASTM D 1092 : NLGI 2 - Base oil @40 °C ASTM D-445: Approx. 260 mm ² /s - Service temperature: -10 ~ 150 °C
Mineral oil, Li-comp.	- Consistency grade ASTM D 1092 : NLGI 2 - Base oil @40 °C ASTM D-445: Approx. 150 mm ² /s - Service temperature: -30 ~ 140 °C
Mineral oil, Al-comp. Graphite solid lubricant	- Consistency grade ASTM D 1092 : NLGI 00 - Base oil @40 °C ASTM D-445: Approx. 500 mm ² /s - Service temperature: -10 ~ 120 °C
Mineral oil, Al-comp. Graphite solid lubricant	- Consistency grade ASTM D 1092 : NLGI 0 - Base oil @40 °C ASTM D-445: Approx. 680 mm ² /s - Service temperature: -10 ~ 120 °C
Mineral oil, Li-comp. MoS ₂ and graphite	- Consistency grade ASTM D 1092 : NLGI 1 - Base oil @40 °C ASTM D-445: Approx. 1,500 mm ² /s - Service temperature: -10 ~ 150 °C



Product details

Product Name	Properties
LUBCHEM GE 5500 MF	Adhesive lubricant with good wear and corrosion protection for increased component lifetime. The product can be used for curved gear couplings and drive chains subject to moisture. High operational reliability is ensured by solid lubricants with emergency lubricating properties.
LUBCHEM GE 5500 S	Adhesive lubricant with good wear and corrosion protection and hydrocapillary effect (displaces water from the friction point), especially for chains subject to moisture. The lubricant contains a solvent for better penetration of the lubricant into the chain links.
LUBCHEM GM oils 100/150/220	high performance and multi-purpose gear oil with high resistant to scuffing, excellent anti-ageing and oxidation, also anti-wear properties.
LUBCHEM GM...S oils 100/150/220/320	Synthetic high-performance and multipurpose oil offering the following advantages over mineral oil of the same viscosity: <ul style="list-style-type: none"> - Significantly longer oil lifetime due to excellent ageing and oxidation stability - Lower operating temperature and improved efficiency due to a reduction of power losses through the optimum friction behaviour of the synthetic base oil - For use at both high and low temperatures - Better load-carrying capacity of the oil film at operating temperatures above 40 °C due to better viscosity-temperature behaviour
LUBCHEM HD oils	Hydraulic oil
LUBCHEM PSI	Synthetic compressor oil for oil-injected process gas compressors operated with refrigerants based on hydrocarbon (propane, butane, propylene, etc.). Very resistant to dilution and absorption by hydrocarbon-containing gases compared to mineral oils. Its longer oil lifetime reduces costs.
LUBCHEM SH	Synthetic air compressor oil for low maintenance and operational costs due to longer oil change intervals. Low formation of oxidation residues in the oil circuit. Longer lifetime of oil filters and separators compared to mineral oils.
LUBCHEM PT 6070 MR	High-performance, white lubricating paste for positive and power-locking connections, e.g. screws on propeller blades. Its high pressure absorption capacity protects against wear, also under high surface pressure. The product reduces wear caused by vibrations and protects against tribocorrosion. LUBCHEM PT 6070 MR is water and leach-resistant, facilitating long-term lubrication. Its good corrosion protection increases component lifetime.
LUBCHEM PT 6080 PE	Black lubricating and assembly paste for bolted connections and connections at the turbocharger and exhaust gas lines. Facilitates easy loosening of bolted connections also after high and long-lasting thermal load. Dry lubrication is attained at temperatures above 200 °C.
LUBCHEM VL 3102	Lubricating grease with high resistance against media. Good sealing effect due to its good water resistance.



Composition	Specification
Mineral oil, P.A.O, MoS ₂	- Base oil viscosity @40 °C, ASTM D-445 Approx. 4,750 mm ² /s - Service temperature: -5 ~ 120 °C
Mineral oil, P.A.O	- Base oil viscosity @40 °C, ASTM D-445 Approx. 4,750 mm ² /s - Service temperature: -5 ~ 120 °C
Mineral oil	- Base oil viscosity @40 °C, ASTM D-445 Approx. 100, 150, 220 mm ² /s - Service temperature: -5 ~ 100 °C
P.A.O	- Base oil viscosity @40 °C, ASTM D-445 Approx. 100, 150, 220, 320 mm ² /s - Service temperature: -10 ~ 100 °C
Mineral oil	- Base oil viscosity @40 °C, ASTM D-445 Approx. 32, 46, 68 mm ² /s - Service temperature: -12 ~ 120 °C
PAG	- Base oil viscosity @40 °C, ASTM D-445 Approx. 68, 100, 150 mm ² /s
P.A.O	- Base oil viscosity @40 °C, ASTM D-445 Approx. 32, 46, 68 mm ² /s
PAG Li-comp. Solid lubricants	- Consistency grade ASTM D 1092 : NLGI 0 - Base oil @40 °C ASTM D-445: Approx. 350 mm ² /s - Service temperature: -40 ~ 150 °C
P.A.O, Ester, Graphite	- Consistency grade ASTM D 1092 : NLGI 1 - Base oil @40 °C ASTM D-445: Approx. 42 mm ² /s - Service temperature: -40 ~ 1000 °C, over 200°C, dry lubricants
Mineral oil Ba-comp.	- Consistency grade ASTM D 1092 : NLGI 2 - Base oil @40 °C ASTM D-445: Approx. 500 mm ² /s - Service temperature: -10 ~ 150 °C

THE INNOVATIVE LEADER OF SPECIAL LUBRICANTS

SPECIAL LUBRICANTS FOR SHIPS AND
OFFSHORE PLATFORMS



Headquarter | MJ Technopark #206, 20, Dalseo-daero 109-gil, Dalseo-gu Daegu, South Korea
Tel.+82-53-625-4833 Fax.+82-53-582-6723

Factory | 172, Dasansandan-ro, Dasan-myeon Goryeonggun, Gyeongsanbuk-do, South Korea
Tel.+82-54-954-8500 Fax.+82-54-954-0131

www.lubchem.co.kr / lub99@lubchemkorea.co.kr